

WHAT IS TAN Δ , OR TAN DELTA?

Tan Delta, also called Loss Angle or Dissipation Factor, is a diagnostic method of testing cables to determine the quality of the cable insulation. This is done to understand the health of the insulation and in order to prioritize scheduled maintenance, replacement, or rejuvenation of the cable system under test.

HOW DOES IT WORK?

If the insulation of a cable is free from defects, like water trees, electrical trees, and other defects, the cable approaches the properties of a perfect capacitor. It is very similar to a parallel plate capacitor with the conductor and the neutral being the two plates separated by the insulation material.

In a perfect capacitor, there is a phase shift between the current and voltage, where the current leads the voltage by 90 degrees. If there are impurities in the insulation, like those mentioned above, the resistance of the insulation decreases, resulting in an increase in resistive current through the insulation. It is no longer a perfect capacitor and the phase shift between the current and voltage will be less than 90 degrees. The extent to which the phase shift is less than 90 degrees is indicative of the level of insulation degradation, hence quality/reliability. This “Loss Angle” is measured and analyzed.

Below is a representation of a cable. The tangent of the angle δ is measured. This will indicate the level of resistance in the insulation. By measuring I_R/I_C , we can determine the condition of the cable insulation. In a perfect cable, the angle would be nearly zero. An increasing angle indicates an increase in the resistive current through the insulation, meaning contamination. The greater the loss angle, the greater the degradation in the cable.

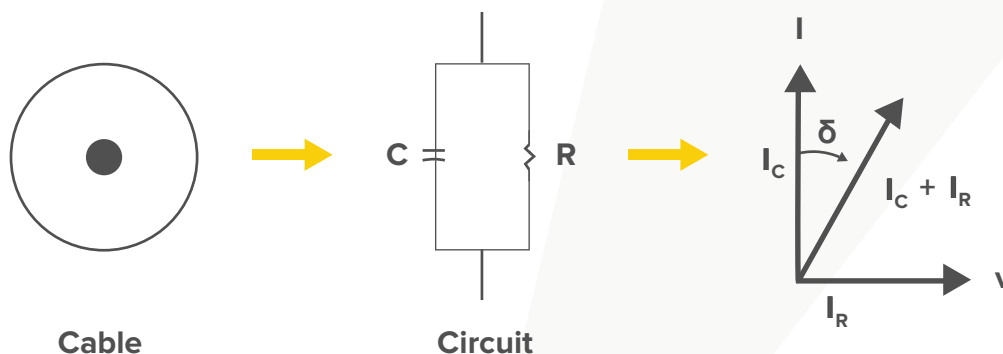

Tan Delta FAQ

WHAT ARE WATER TREES?

Water trees are small tree shaped channels found within the insulation of a cable, caused by the presence of moisture. They may appear in service aged XLPE and other solid dielectric insulations, like PE and EPR type cables. These tree shaped moisture channels, in the presence of an electrical field, eventually lead to the formation of electrical trees which grow to a point where insulation failure occurs. The tan delta test shows the extent of water tree damage in a cable.

WHAT HARDWARE IS NECESSARY?

The TD-65E tan delta transducer analyzes the voltage and current waveforms and calculates the tan delta number. A wirelessly connected laptop computer can be used to display and store the results.

A voltage source is needed to energize the cable. In this case, a Very Low Frequency (VLF) AC Hipot. The VLF-34E pictured here is a 34 kV (peak) unit that is capable of testing from $0.5\mu\text{f}$ of cable load at 0.1 Hz, up to $5.0\mu\text{f}$ at 0.01 Hz. VLF hipots are also widely used for testing newly installed and/or repaired cable before reenergizing to insure the cable is sound and for testing critical cable runs.

Model	TD-65E
Input	Two Alkaline "D" cell batteries required – Four supplied rechargeable "D" cell batteries acceptable – Not included
Metering	Voltage: 1-65kVp(46kVrms), $\pm 1\%$ Accuracy, 0.1kV Resolution Current: 0-150mA(106mArms), $\pm 1\%$ Accuracy, 1uA Resolution Tan Delta: 0.1Hz -0.01Hz, 5nF-10uF, 1.0×10^{-4} Accuracy, 1.0×10^{-5} Resolution
PC Interface	XBee 802.15.4 (wireless, ~30ft range)
PC Software	E-Link remote control and report generation software
Interconnect Cables	88-5061 - 20ft/6.1m VLF output cable for use with VLF-34E 81-5220 - 20ft/6.1m VLF output cable for use with VLF-65E (Sold Separately)
Included Cables	10ft/3m TD output lead terminated with red banana clip, 20ft/6.1m green/yellow test lead, 2in/51mm x 5in/127mm toroid, 1 1/2in/38mm aluminum ball with banana socket
Size	TD Transducer w/ Tripod: 7in/152mm x 8in/203mm x 18in/457mm TD Carrying Case: 22.5in/572mm x 15in/381mm x 11.75in/298mm
Weight	TD Transducer with Tripod: 7lb/3.2kg TD w/ Carrying Case and Accessory Bag: 40lb/18.14kg



HOW IS THE TEST PERFORMED?

The cable to be tested must be de-energized and each end isolated. Using a VLF AC Hipot, the test voltage is applied to the cable while the tan delta controller takes measurements. The applied test voltage is raised in steps, 0.5, 1.0 and 1.5U₀ for three minutes each step. The tan delta numbers at the higher voltages are compared to those at lower voltages and an analysis is made.

WHY IS A VLF HIPOT USED INSTEAD OF A REGULAR 60 HZ MODEL?

To test a cable with 60 Hz power requires a very large high voltage supply. It is not practical, nearly impossible, to test a cable of several thousand feet with a 60 Hz supply. At a typical VLF frequency of 0.1Hz, it takes 600 times less power to test the same cable compared to 60 Hz.

The magnitude of the tan delta numbers increase as the frequency decreases, making measurement easier. As the below equation shows, the lower the frequency (f), the higher the tan delta number.

$$\text{Tan Delta } (\delta) = IR/IC = 1/(2\pi fCR)$$

HOW ARE THE TEST RESULTS INTERPRETED? AND IS IT NECESSARY TO HAVE A BENCHMARK, OR STANDARD, RESULT TO COMPARE TO?

While it is beneficial to have a standard or previous test to compare to for trending purposes, like with many diagnostic methods of testing, it is not necessary. The very first test on a cable yields valuable information about the insulation.

If the cable insulation is perfect, the loss factor (tan delta) will not change as the applied voltage is increased. The capacitance and loss will be similar with 1 kV or 10kV applied to the cable. If the cable insulation is contaminated, changing the capacitive/resistive nature of the insulation, then the tan delta numbers will be higher at higher voltages. Rather than a flat curve for the loss number versus voltage, the curve will be non linear. See the graph below.

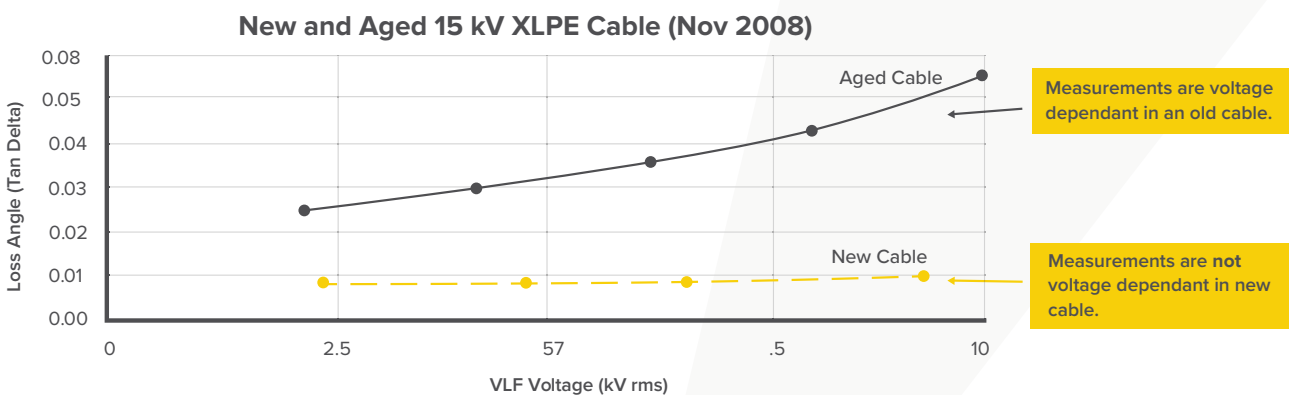

Tan Delta FAQ

From the graph on the previous page, the Loss Angle increases with increasing voltage, indicating a high resistive current element to the insulation. These results can be compared to the condition assessment criteria within IEEE 400.2 or to other cables tested to determine which cables are in need of immediate corrective action and which can wait a bit longer. Also, many tests are measured on a comparative basis allowing results to be ranked from least healthy to most healthy.

ARE THERE REFERENCE POINTS AND APPLICABLE STANDARDS?

The Cable Diagnostic Focus Initiative, (CDFI) conducted by National Electric Energy Testing Research and Applications Center (NEETRAC) has produced volumes of data related to this field. This is an invaluable resource that should be accessed by those conducting Tan Delta tests on shielded cable systems. Neetrac operates within the Electrical and Computer Engineering School at Georgia Tech. The IEEE standard 400.2 also includes cable assessment criteria based on insulation type that the user can reference.

Condition Assessment Criteria

*All numerals are 10-3 per Section 5, Tables 4 & 5 of IEEE 400.2-2013

Condition Assessment	No Action Required	Further Study Advised	Action Required	No Action Required	Further Study Advised	Action Required	No Action Required	Further Study Advised	Action Required
Insulation Type	PE Based Insulation (PE, XLPE, WTRX-LPE)			Unidentified Filled Insulation (EPR)			Mineral Filled Insulation (EPR)		
Stability for TD (Standard Deviation)	< 0.05	0.05 to 0.5	> 0.5	> 0.1	0.1 to 1.3	> 1.3	< 0.1	0.1 to 1	> 1
	And	Or		And	Or		And	Or	
Tip Up (TD1.5U0 – TD0.5U0)	< 5	5 to 80	> 80	< 5	5 to 100	> 100	< 4	4 to 120	> 120
	And	Or		And	Or		And	Or	
Mean TD @ U0	< 4	4 to 50	> 50	< 35	35 to 120	> 120	< 20	20 to 100	> 100

One must keep in mind the purposes of these tests. Whether using partial discharge or tan delta, the point of the test is to grade all cables tested on a scale from high quality to low. The point of the testing is to help the owner of the infrastructure prioritize cable maintenance, replacement or rejuvenation. Comparative testing will show which cables are worse than others.

IS THERE A POSSIBILITY OF THE CABLE FAILING DURING THE TEST?

Since test voltages of up to $1.5U_0$ are used, there is a possibility of a cable failing during the few minutes needed to perform the test. This can usually be avoided if the tan delta numbers are monitored at the lower test voltages. If the tan delta results indicate an unhealthy cable, the test can be stopped prior to cable failure.

HOW LONG OF A CABLE CAN I TEST?

The Tan Delta bridge does not limit the length of cable that can be tested, however the VLF source does. It is generally advantageous to test shorter sections rather than long cable systems.

CAN THE TEST FIND THE LOCATIONS OF CABLE DEFECTS?

Tan delta is a global assessment of the insulation system. Tan delta is not a fault-finding tool, it is a tool to gather information to make educated decisions regarding the health of the insulation of the cable system under test.

In some situations, a better test may be to use the VLF hipot and apply the IEEE 400.2 recommended test voltage for at least 30 minutes. Any defect severe enough to be excited by the test voltage applied will fail. Find the fault, repair it, and move on.

ISN'T THIS THE SAME AS A POWER FACTOR TEST?

Not quite, although it essentially provides the same qualitative assessment as a power factor test. With power factor, the cosine of the angle between the voltage and current is measured, yielding the power factor. With tan delta, we are measuring the tangent of the complimentary angle, and it is measured in radians, not degrees as power factor is done. For slight angles, the tan delta readings will be the same as power factor. As the angle, hence dielectric loss increases, the tan delta numbers and the power factor numbers will not be the same.

ARE THERE ANY LIMITATIONS TO USING TAN DELTA TESTING?

Since we are measuring the loss angle of an insulating material, and making an analysis about the test results based on historical data as well as comparing to IEEE 400.2 cable assessment criteria, it is not advisable to test a cable system that contains more than one type of insulation. Different cable insulations have different loss characteristics. It is not a good test to test a cable length with XLPE insulation spliced to an EPR or PILC cable. Bad tan delta numbers caused by degraded XLPE insulation may be masked by dielectrically healthy EPR or PILC insulations. The only way in which this is meaningful is when many tests are done on the same cable length over time and the results are carefully trended.

CONCENTRIC NEUTRAL

Since we are measuring the loss angle between the conductor and the outer shield, the outer shield must be intact. It is advisable to test the integrity of the concentric neutral before performing any high voltage withstand or diagnostic test. This is a worthwhile test for several reasons, whether or not a tan delta test is being performed. If there are large gaps in the neutral, the tan delta numbers will not be as meaningful.

Tan Delta FAQ

the neutral was intact. There are easy ways to test the integrity of the neutral. Please contact HVI for more information.

HOW LONG DOES THE WHOLE TEST TAKE?

The test itself takes approximately 9 minutes. Per the IEEE 400.2 standard, you will need a minimum of 2 minutes of stable tan delta readings at each test voltage. As the first 1 to 2 cycles could be unstable during the initial ramp to the desired test voltage. HVI recommends a minimum of 3 minutes at 0.5, 1.0 and 1.5U₀.